



ENERGY STAR® Qualified Atmospheric Vented Gas Water Heaters

The John Wood® ENERGY STAR® Qualified Atmospheric Vented Gas Water Heater complies with 2010 ENERGY STAR® qualifications and has an impressive .67 energy factor (EF). With an installed flue damper, higher efficiencies can be achieved therefore saving you money.

Flame Guard® patented technology prevents the ignition of flammable vapours from products such as gasoline, paint thinner and solvents. Subjected to over 1,000 tests including lint, dust and oil, butane and endurance burn, the Flame Guard® system is the safest and most proven technology available today.



PRODUCT FEATURES

- Same tank diameter as existing 0.62 EF models
- ENERGY STAR® qualified
- Flue damper for increased EF and performance
- 24 volt gas valve
 - Diagnostic capabilities
 - Monitors damper for increased performance and safety
 - Modular valve for ease of replacement
 - Spark ignition eliminating standing pilot
- Includes a 20 foot 24-volt power cord that can be increased up to 50 feet

LONG-LASTING DEPENDABILITY MEANS YEARS OF ASSURANCE

- Glass-lined flue prevents scaling
- Top mounted heavy duty anode rod for added tank protection
- Robust 1/4" pilot tubing

BENEFITS OF THE FLAME GUARD® SYSTEM

Servicing made simple - saves you time and money

- Combustion chamber is easy to access
- T&P valve is conveniently located at the side of the tank to facilitate piping to a drain or outside the building
- Dependable three-leg design for better leveling and access to flame arrestor



ENERGY STAR® QUALIFIED ATMOSPHERIC VENTED GAS WATER HEATERS

Models	CAPACITY			BTU Input	RECOVERY @ (100°F/45°C)			Energy Factor	A	B	C	D	Draft Hood Connector (in.)	Approx. Ship Wt. lb/kg
	Imp. Gal	US Gal	Litres		USG/h	IG/h	Litres/h		JACKET DIA. in/cm	Top of Vent in/cm	Top of Heater in/cm	Height to Gas Inlet in/cm		
NATURAL GAS - 8 and 2 Year Warranty														
JW840S38ES2	33	40	151	38,000	32	27	122	0.67	21/53.34	55.75/141.6	49.1/124.8	12.5/31.75	3 & 4	138/63
JW850S40ES2	42	50	189	40,000	34	28	128	0.68	22.5/57	57.25/145.4	50.6/128.6	12.69/32.23	3 & 4	170/77
NATURAL GAS - 6 and 1 Year Warranty														
JW640T40ES2	33	40	151	40,000	34	28	128	0.67	19/48.3	66.13/168	59.5/151.1	13.5/34.29	3 & 4	135/61
JW650T40ES2	42	50	189	40,000	34	28	128	0.68	21/53.34	64.75/164.5	58.1/147.6	12.25/31.12	3 & 4	168/76

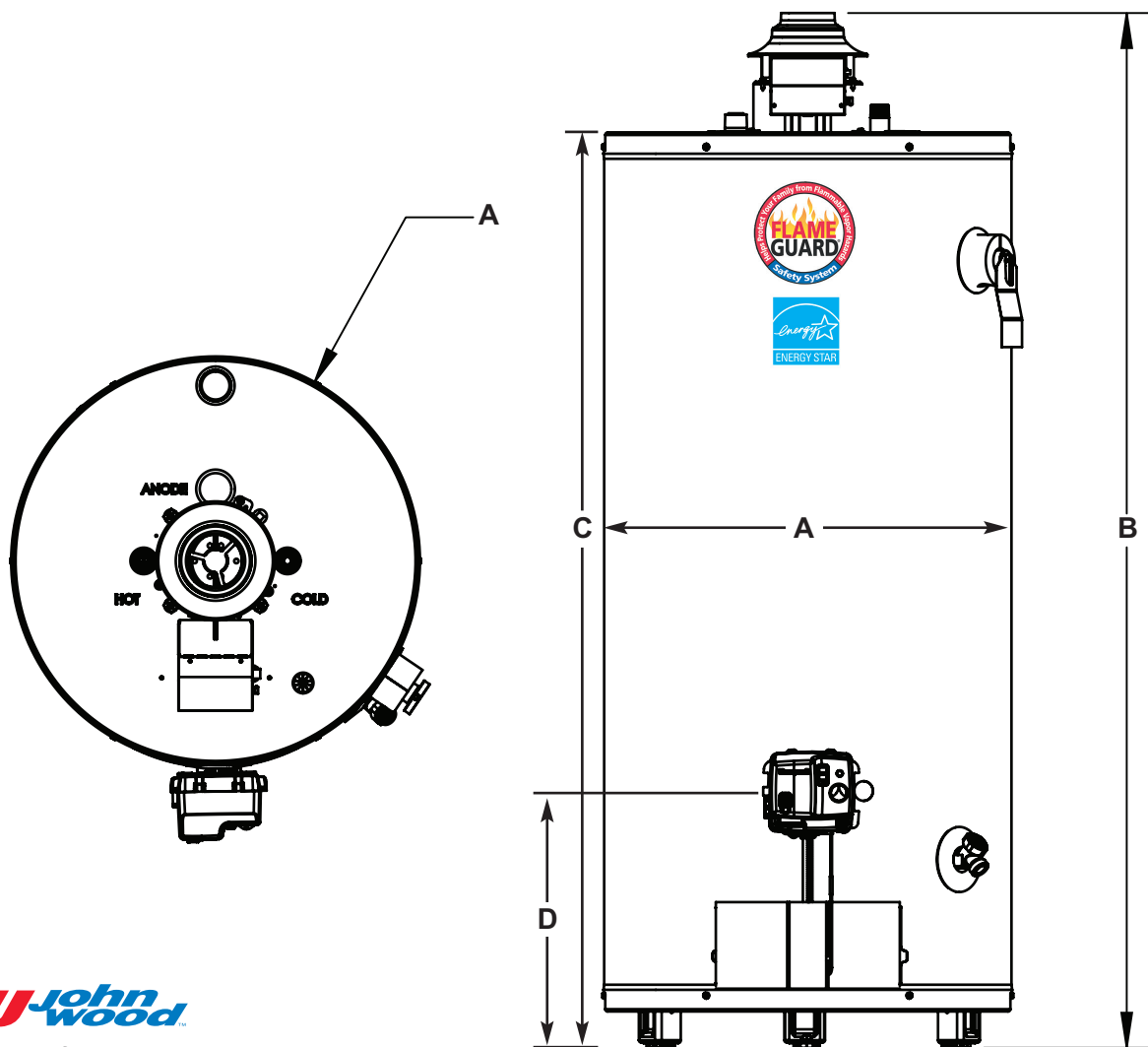

For more information, visit our website at:
www.johnwoodwaterheaters.com

GSW Water Heating

599 Hill Street West,
 Fergus, Ontario, Canada N1M 2X1
 Sales/Customer Service: 1-888-599-2837
 Fax: 1-519-787-5500
 Technical Support and Warranty: 1-888-479-8324
 E-mail: info@gsw-wh.com

GSW Warranty:

All GSW and John Wood® Water Heaters will be replaced free of charge in the case of tank leakage within the stated warranty period from the date of installation in domestic applications, and one year in commercial applications. All parts supplied are warranted for one year. Warranty does not include labour. Consult owner's manual for complete details.

